



- *Reduction of NO_x values*
- *Helps meet the Euro 5 standard*
- *Use in combination with intercooler*

Product features



1 Radiator for exhaust gas recirculation
2 Intercooler

- New radiator for exhaust gas recirculation to meet the Euro 5 standard.
- The Euro 5 limits are not exceeded thanks to the combination of cooled exhaust gas recirculation (EGR) and charging with intercooling.
- Efficient intercooling and exhaust gas cooling have a positive influence on both NO_x formation in the combustion chamber and fuel consumption.

How exhaust gas recirculation works

The effect of exhaust gas recirculation is mainly due to the fact that the exhaust gas has a greater heat capacity and lower oxygen content than air. This reduces the combustion temperatures in the cylinder. Temperatures reduced even further by cooling of the exhaust gas and the charge air. Since the formation of NO_x depends exponentially on these temperatures, a combination of cooled exhaust gas recirculation and charging with intercooling enables the limits of the Euro 5 standard to be met. Efficient intercooling and exhaust gas cooling have a positive influence on both NO_x formation in the combustion chamber and fuel consumption.

The two systems of exhaust gas recirculation

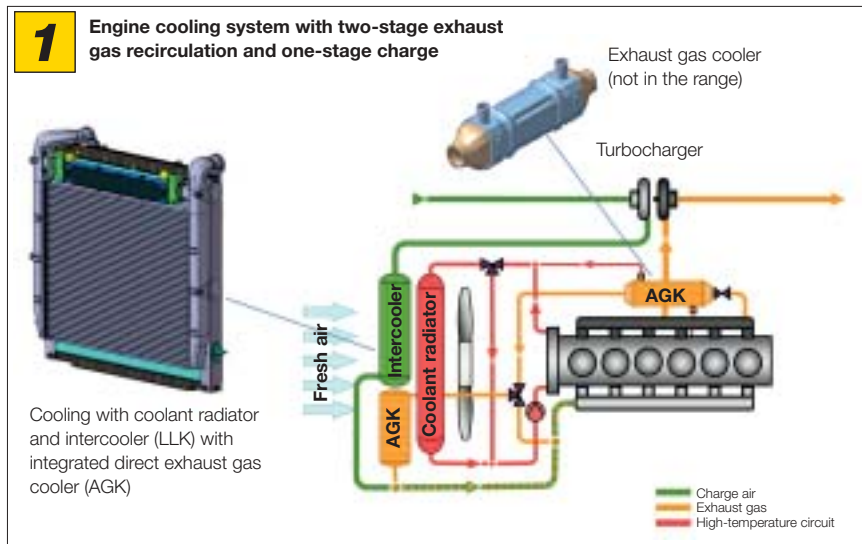

Engine cooling system with two-stage EGR and one-stage charge

With this system, the exhaust gas to be recirculated is routed to an exhaust gas cooler cooled by coolant. Then it is routed to an air-cooled exhaust gas cooler, that is directly integrated in the intercooler. In this second cooler, the exhaust gas temperatures are reduced further from 150 – 200 °C by an airflow which, depending on the driving speed, is generated by the fan and/or wind blast. Since the exhaust gas in this system is cooled in two stages, the resulting exhaust

gas temperatures are lower, and a one-stage charge with intercooling is sufficient to meet the Euro 5 standard. Thanks to this cooling system, exhaust gas and charge air can be brought to about the same temperature level, which leads to a significant reduction in the mixing temperature upstream from the intake manifold.

Since most of the components are installed directly in the vehicle front-end, they are often affected as so-called “crash parts” in the event of rear-end collisions. In addition, they can also be exposed to influences such as e.g. gravel throw.

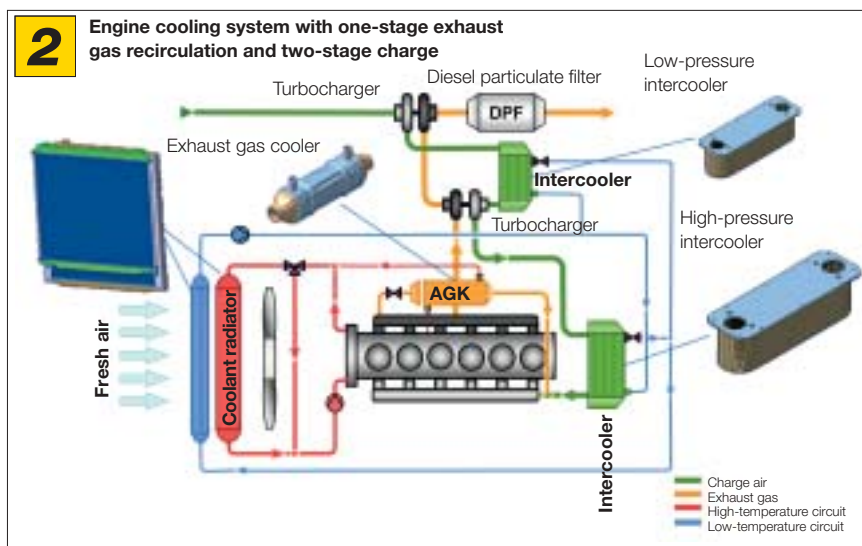

Engine cooling system with one-stage EGR and two-stage charge

This circuit includes an exhaust gas cooler which reduces exhaust temperatures through coolant. A low-temperature circuit with two intercoolers and one low-temperature coolant radiator is also integrated. Since the low-temperature coolant radiator has a large end face and is flooded first by the cooling airflow, very low charge temperatures can be achieved. This system is termed indirect intercooling. In the EGR radiator, the returning exhaust gas part flow taken from the engine

at the exhaust manifold is cooled and then mixed with the charge air upstream from the intake manifold. The reduction in temperature of the whole intake air this causes reduces the formation of NO_x .

Behr Hella Services does not have the components for this system in its range at the moment, since they are not relevant for the aftermarket.

Technical details

Technical data

Material	Stainless steel block (extremely heat-resistant) Aluminium air boxes
	Pipe-rib and rib-block cover plate connections High-temperature nickel-soldered

Technical drawings

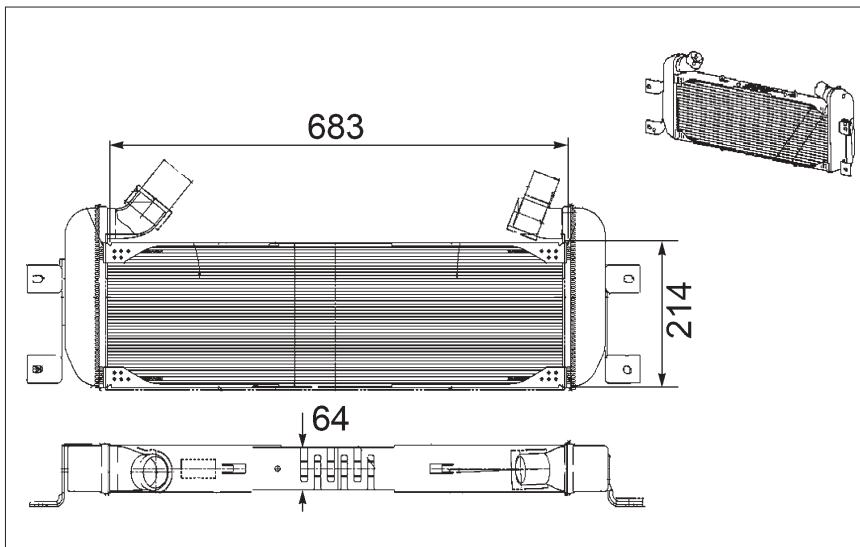

Scania R series
8ML 376 756-191

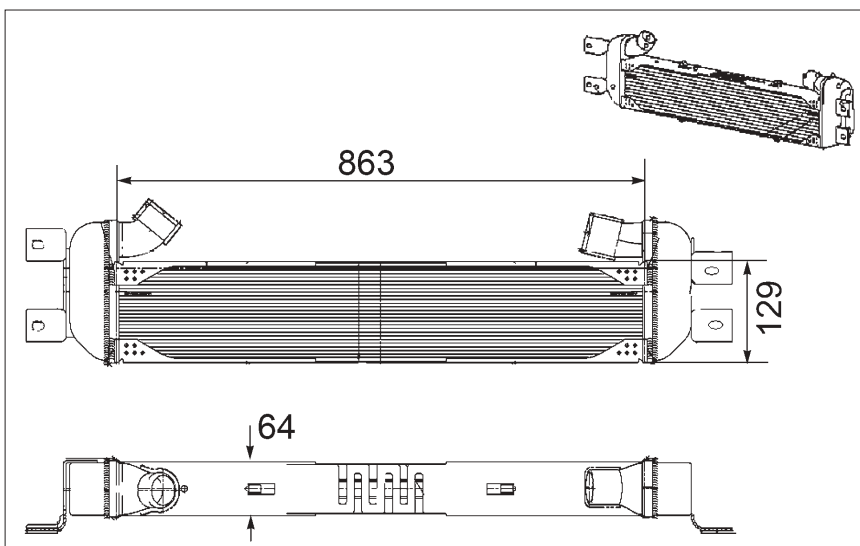

Scania P series
8ML 376 756-211

Product overview

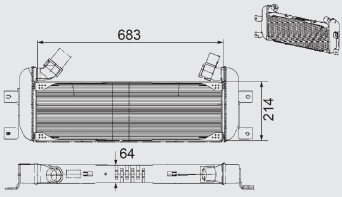
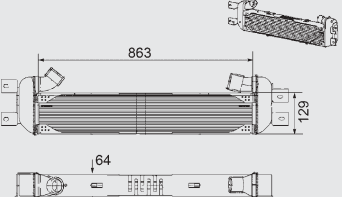
Product photo	Part number	Description	OE number*	Use
	8ML 376 756-191	Radiator for exhaust gas recirculation	1764094	Scania R series
	8ML 376 756-211	Radiator for exhaust gas recirculation	1752543	Scania P series

Intercooler with respective recess for EGR radiator

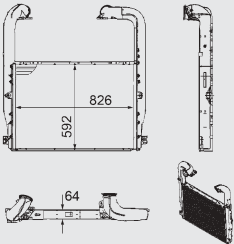
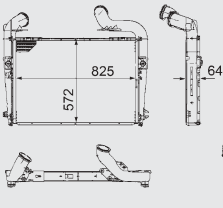
Product photo	Part number	Description	OE number*	Use
	8ML 376 756-201	Intercooler	1747660	Scania R series
	8ML 376 756-181	Intercooler	1769998	Scania P series

* OE numbers are only for comparative purposes